

Copyright Scientific Specialties, Inc.
This drawing and/or any technical information relating to it is issued in strict confidence and may not be reproduced or used for manufacture without written permission. Upon receipt of which it is the user's responsibility to seek confirmation of any dimensions and production tolerances.

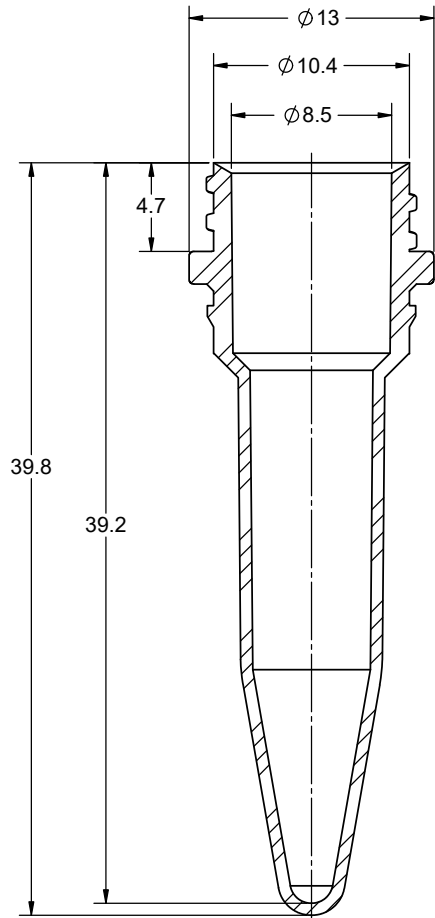

SECTION A-A
SCALE: 5 : 1

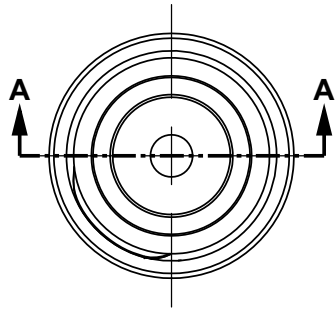
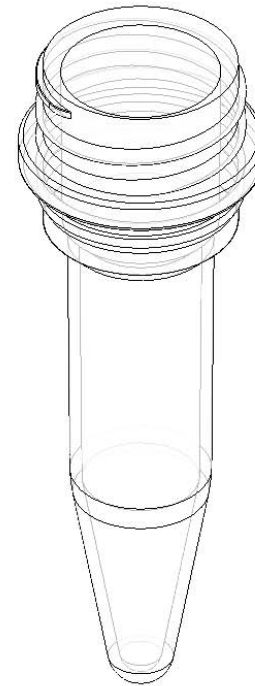

SSI
1310 Thurman Street
Lodi, CA 95240
Ph: (209) 333-2120
F: (209) 333-9623
info@scientificspecialties.com

TITLE: *0.50mL SCREW CAP TUBE - STD*

UNLESS OTHERWISE SPECIFIED
DIMENSIONS ARE IN MILLIMETERS

ITEM:
2130-00

REV.:
2

DATE:
6/23/2020