

SECTION A-A  
SCALE: 5 : 1

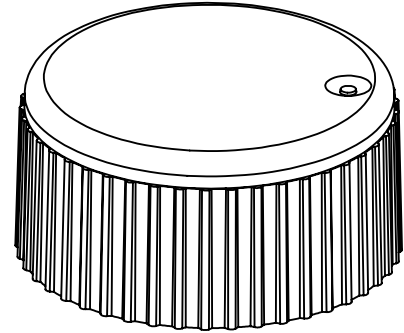

UNLESS OTHERWISE SPECIFIED  
DIMENSIONS ARE IN MILLIMETERS

CAD GENERATED DRAWING,  
DO NOT MANUALLY UPDATE

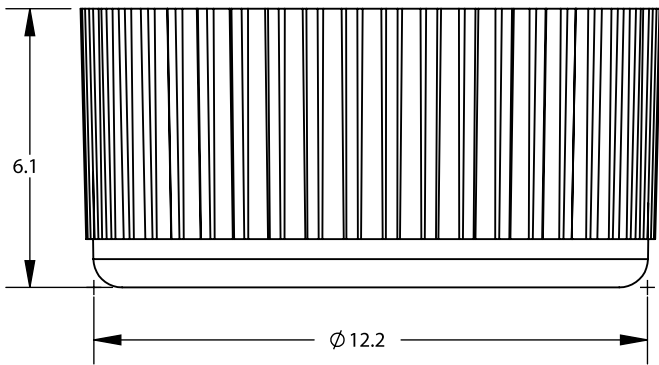
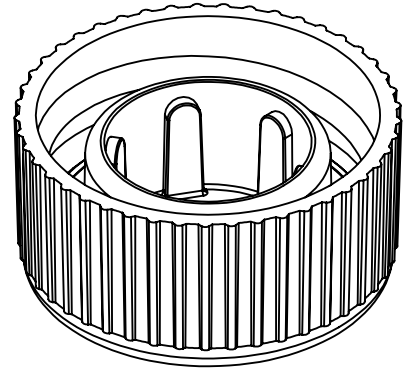

1310 Thurman Street  
Lodi CA, 95240  
Ph: (209) 333-2120  
Fx: (209) 333-8623  
info@scientificspecialties.com

	APPROVALS		DATE
	DRAWN: P. DO	CHECKED:	3/21/2018
SSI MATERIAL:	RESP ENG:		
MANUFACTURER'S MATERIAL:	MFG ENG:		
FINISH:	QUAL ENG:		
DO NOT SCALE DRAWING			

<b>2001-XX</b>		REV.: REL
<i>SCREW CAP ASSEMBLY</i>		
SIZE: A	SHRINK RATE:	
SCALE: 1:1	JOB NO.:	SHEET: 1 OF 1

PRINTED 3/21/2018

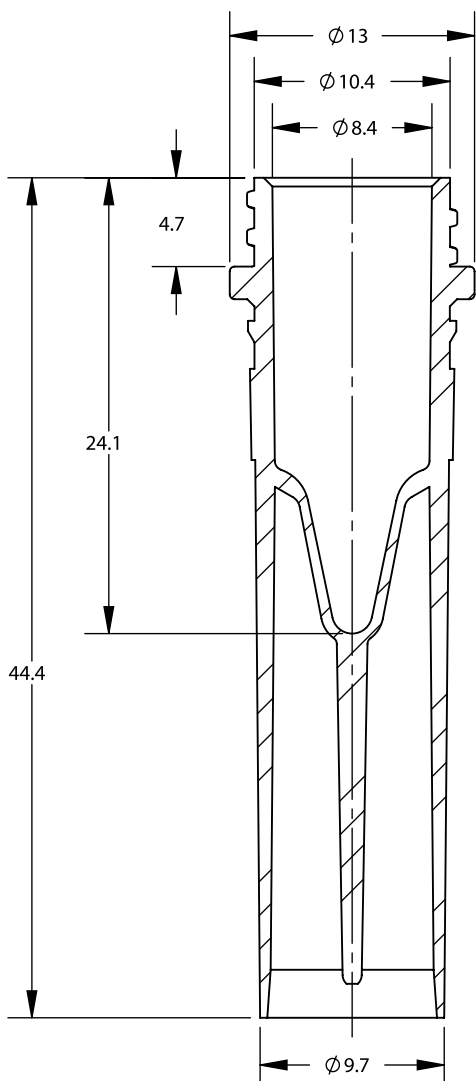
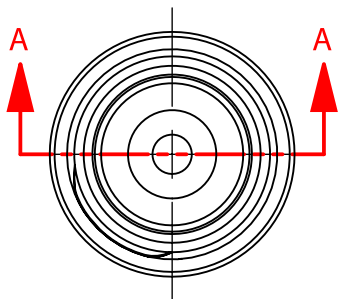

SECTION A-A  
SCALE: 2.5 : 1

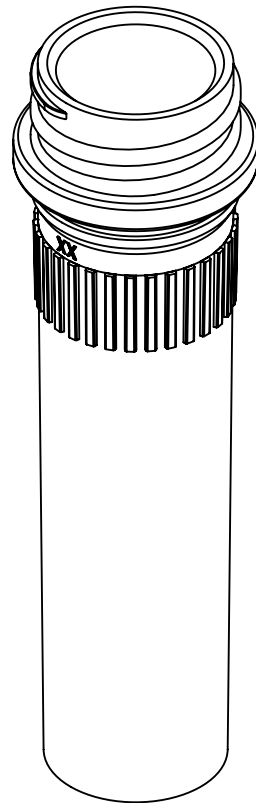

UNLESS OTHERWISE SPECIFIED  
DIMENSIONS ARE IN MILLIMETERS

CAD GENERATED DRAWING,  
DO NOT MANUALLY UPDATE



1310 Thurman Street  
Lodi CA, 95240  
Ph: (209) 333-2120  
Fx: (209) 333-8623  
info@scientificspecialties.com

	APPROVALS		DATE
	DRAWN: P. DO	CHECKED:	7/20/2016
SSI MATERIAL:	DESIGN ENG:		
MANUFACTURER'S MATERIAL:	MFG ENG:		
FINISH:	QUAL ENG:		
DO NOT SCALE DRAWING			

<b>2420-XX</b>		REV.: 3
<i>0.50mL SCREW CAP TUBE-STANDARD</i>		
SIZE: A	SHRINK RATE:	
SCALE: 1:1	JOB NO.:	SHEET: 1 OF 1

PRINTED 7/20/2016