

Scientific Specialties, Inc.

Your OEM and Custom Solutions Provider

Manufacturing industry leading plasticware for the life science and biotechnology industry



Made in the USA



Innovations for Life Science

Scientific Specialties, Inc. (SSI) is a designer and manufacturer of innovative, industry leading plasticware for the life science and biotechnology industry.

For 25 years we have been providing our clients with OEM and custom product solutions tailored to their requirements. All SSI products are made in the USA at our facility in Central California. Our expansive product portfolio includes:

- › [Thin wall PCR consumables](#)
- › [Precision storage, transport and centrifuge tubes](#)
- › [Pipette tips](#)
- › [Tube racks](#)

As an independent company, we personalize our service to fit your needs. From product development to existing product modifications to custom branding and packaging: we have the versatility to create a customized solution and the internal capabilities to make it a reality.

No matter how you choose to partner with us, you'll benefit from decades of expertise, innovative technology, dedicated resources, and first class service that will deliver the best solution in today's demanding market.



Product Design

SSI's dedicated team of designers and engineers utilize industry leading software and hardware to design products.

Our capabilities include:

- › 3D CAD software for conceptual designs that meet your requirements for quality, aesthetics, and product performance
- › The latest in 3D printing technology to prototype parts and accelerate the development process
- › An in-house tooling team can modify molds to facilitate customer-specific dimensional or functional requirements
- › All single and multi-cavity molds are manufactured in the USA

SSI designs and manufactures products that are meticulously engineered, innovative, and relevant to today's market. From new product concepts to modifying existing products, we can support your OEM and custom product needs.

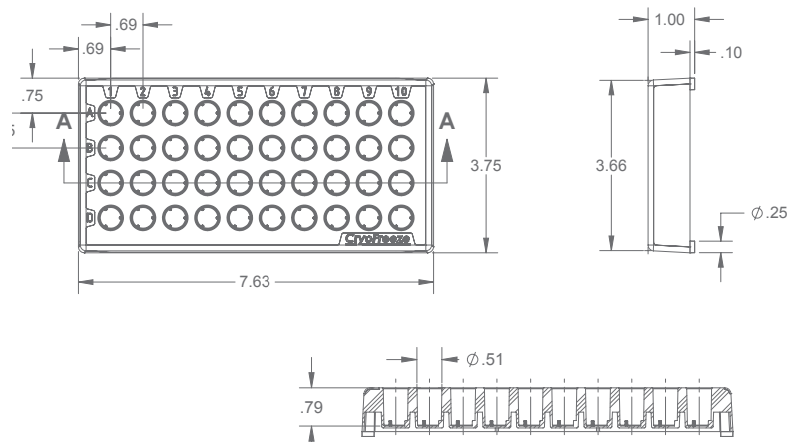
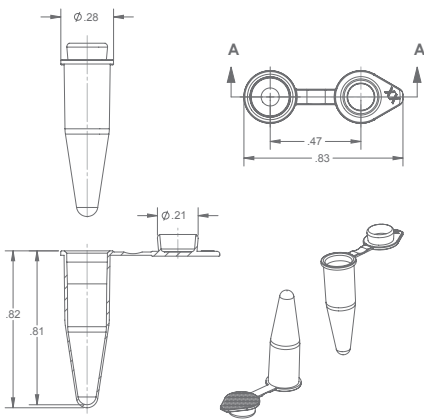

To discuss your project, contact us at oem.custom@ssibio.com.

Manufacturing

Every SSI product is made in the USA in our 11,000 m² (121,000 ft²) facility in Central California. The facility includes 2,500 m² (27,000 ft²) of clean, climate controlled manufacturing space, allowing us to implement rigorous quality standards and process controls to eliminate variables.

Our expertise in injection molding and integration of robotic and automated systems means that we create uniform, precise product and package it in the most efficient manner.

Depending on production needs, we have the flexibility to switch from manual to semi-automated to fully automated operation.

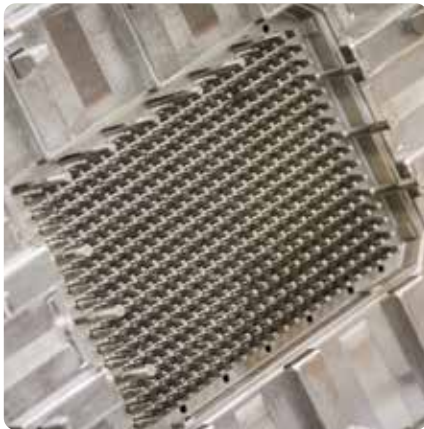

Quality Assurance

Our commitment to quality defines SSI. As an ISO 9001:2008 certified company, it begins with our mission statement: to provide the highest quality product that meets or exceeds the expectations of our customers.

- › Only virgin, medical grade plastics used in PCR, tube, and tip products
- › Independently certified clean product free of RNase, DNase, DNA, and PCR inhibitors
- › On-site Quality Assurance analytical lab features advanced, industry standard equipment
- › Every production run is tracked and inspected, ensuring customers receive product that pass our exacting standards and requirements

We are a fully integrated operation with a renowned track record of providing innovative, quality products to customers.

**ISO
9001
QUALITY
ASSURANCE**

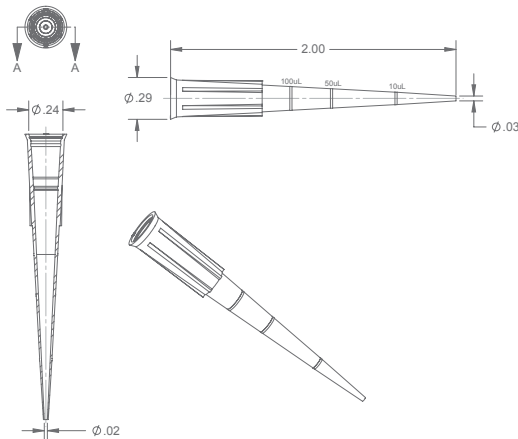

To discuss your project, contact us at oem.custom@ssibio.com.

Custom Barcoding

To support fast, accurate, and automated sample tracking, SSI has barcoding options available on several products including semi-skirted and skirted PCR plates. Our barcode offering features:

- › Industry-standard code 128 symbology
- › Ability to choose the start and end alpha-numeric codes
- › Barcodes applied to any or all sides
- › A robotic barcode application system records and tracks each barcode used, ensuring that every code is unique and machine-readable

With a fully compatible and expandable barcoding platform, our plates can be adapted to any project.

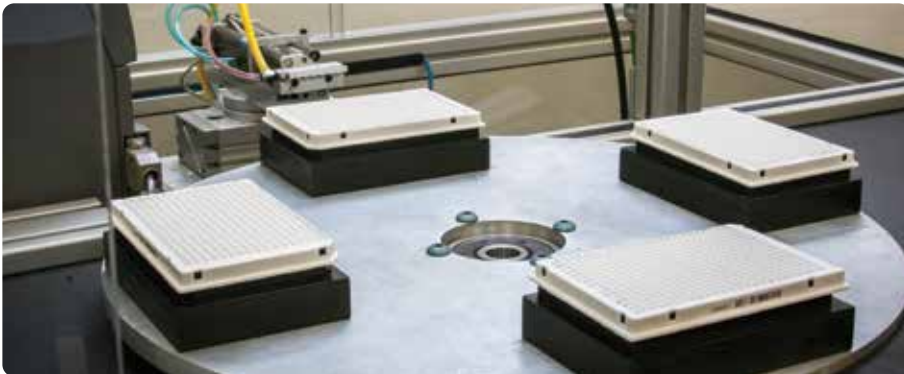

Custom Branding

A key benefit of partnering with SSI is the ability to leverage 25 years of branding experience. We have an in-house, dedicated branding team to translate your needs into a custom solution, whether that need is a customized label or a custom-designed unit box. Our standard product is offered in plain white boxes with non-branded labeling while our OEM product is customizable to multiple packaging configurations:

- › Unit boxes with your artwork applied
- › Unit packaging using your labels, either printed in house or supplied to us
- › Labels can accommodate 2D barcodes, with many symbology available including the GS1-128 standard

From designing and manufacturing innovative products to creating OEM and custom branding solutions, we have expertise across the entire value chain.



To discuss your project, contact us at oem.custom@ssibio.com.

With decades of experience, a commitment to quality, and service tailored to each project, SSI can meet all your OEM and custom product needs. To discuss your project, contact us at oem.custom@ssibio.com.



1310 Thurman Street, Lodi, CA 95240
ssibio.com | oem.custom@ssibio.com
+ 1 (209) 333-2120 | Fax: + 1 (209) 333-8623



Made in the USA